

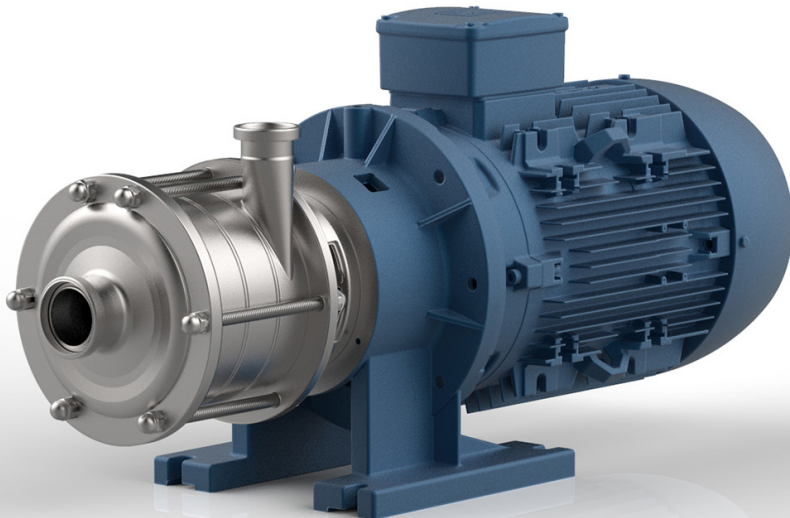

CENTRIFUGAL SINGLE-STAGE AND MULTISTAGE PUMPS

CSM series



Multistage CSM pump version X

In general CSM multi-stage pumps are suitable for high-pressure duties with medium-low flow rates and for use with high suction pressure: reverse osmosis plants for water demineralization and purification, whey dehydration, fruit juice concentration, enzyme selection and concentration and for reducing the alcohol content in beer and wine; nanofiltration and ultrafiltration plants for milk and whey treatment, lactose removal, salt and/or protein selection; membrane treatment of industrial wastewater.

CSM Series, extremely robust stainless steel pumps designed for high pressure duties with medium to low flow rates; especially suitable for applications with high suction or system pressures. Made from solid CF-3M 1.4404 / AISI 316L stainless steel, the wetted parts have a high surface finish and electro-chemical polish. Single-stage and multistage models with up to 4 impellers. Available in three different versions. Standard CSM: Close coupled design using a standard motor, with a separate pump shaft supported by bearings.

“CSMX” version: Close coupled to a standard motor, with a foot mounted housing containing single or double shaft support bearings.

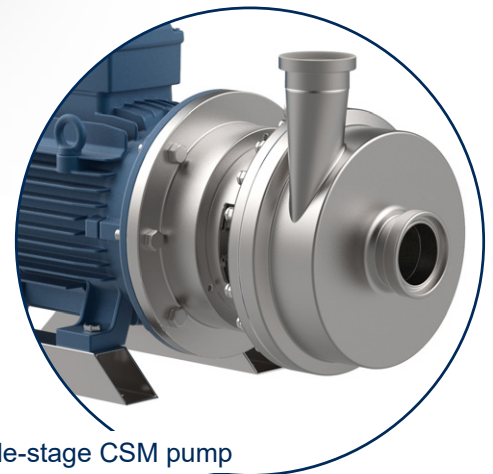

Single-stage CSM pump

TECHNICAL DATA

Flow rates up to 50 m³/h for the multistage versions
Heads up to 150 m (15 bar) for the multistage versions.
Flow rates up to 150 m³/h for the multistage versions
Heads up to 60 m (6 bar) for the single-stage versions.
Design pressure 40 bar
Temperature range: 0 to 100°C.

Seals:

Protected, balanced and bi-directional mechanical seals with seats to EN12756, ISO3069 standards.
Single internal mechanical seal
Single internal flushed mechanical seal

Seal materials (FDA and Regulation (EC) No. 1935/2004):

Ethylene propylene (EPDM)
Fluorocarbon (FPM-FKM)
FEP
NBR

Connections:

Flanges EN1092-1 PN40, Clamp for high pressures, DIN 11851 / 11864-1 up to 25 bar

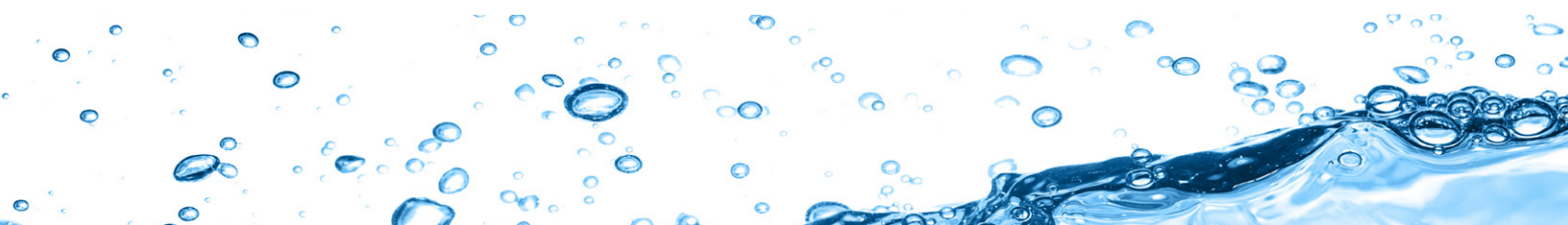

GENERAL DIAGRAM CSM MULTISTAGE
 (Performance applies to H₂O at 20 °C, 1013 mbar, Data not binding)

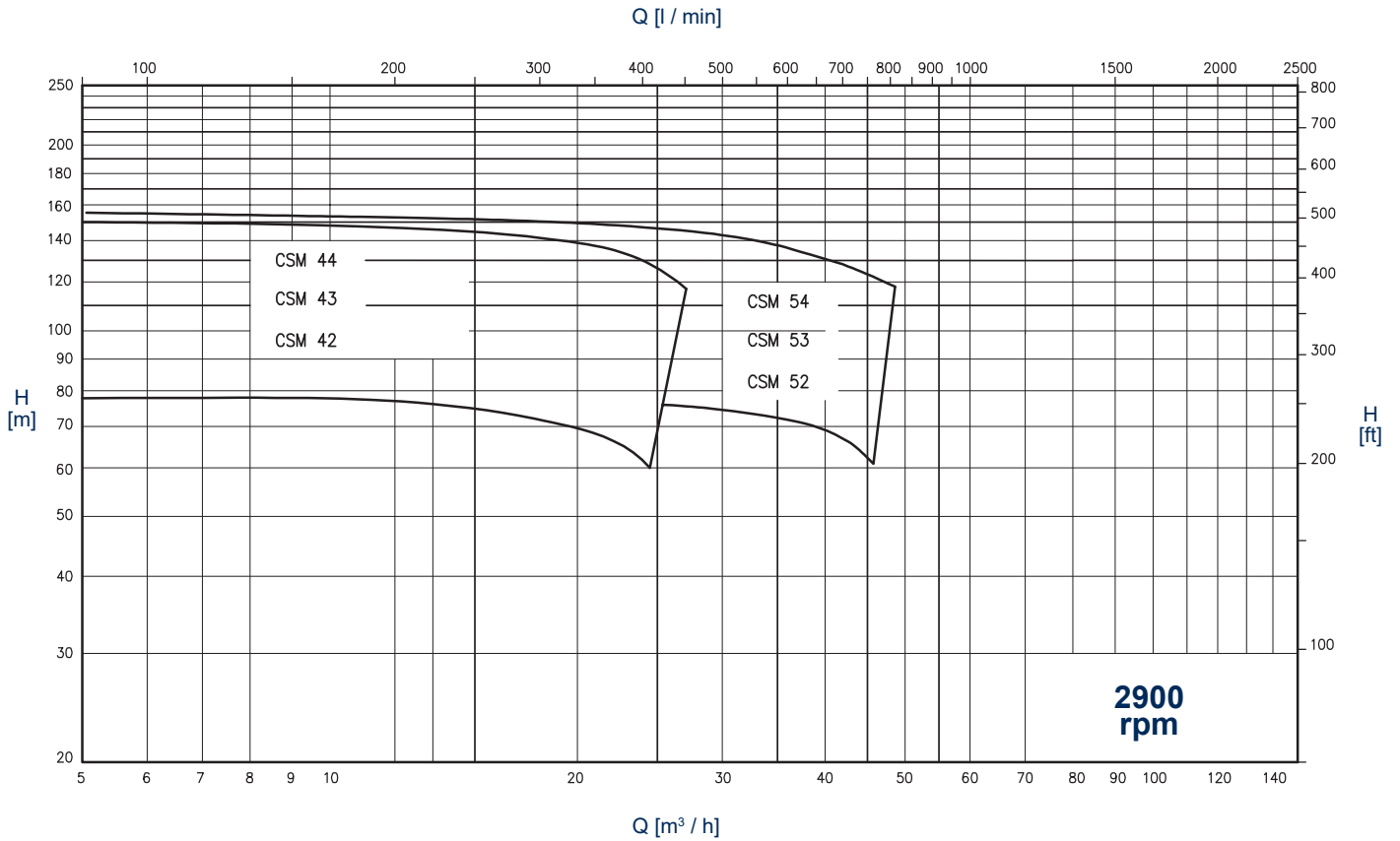

GENERAL DIAGRAM CSM SINGLE-STAGE
 (Performance applies to H₂O at 20 °C, 1013 mbar, Data not binding)

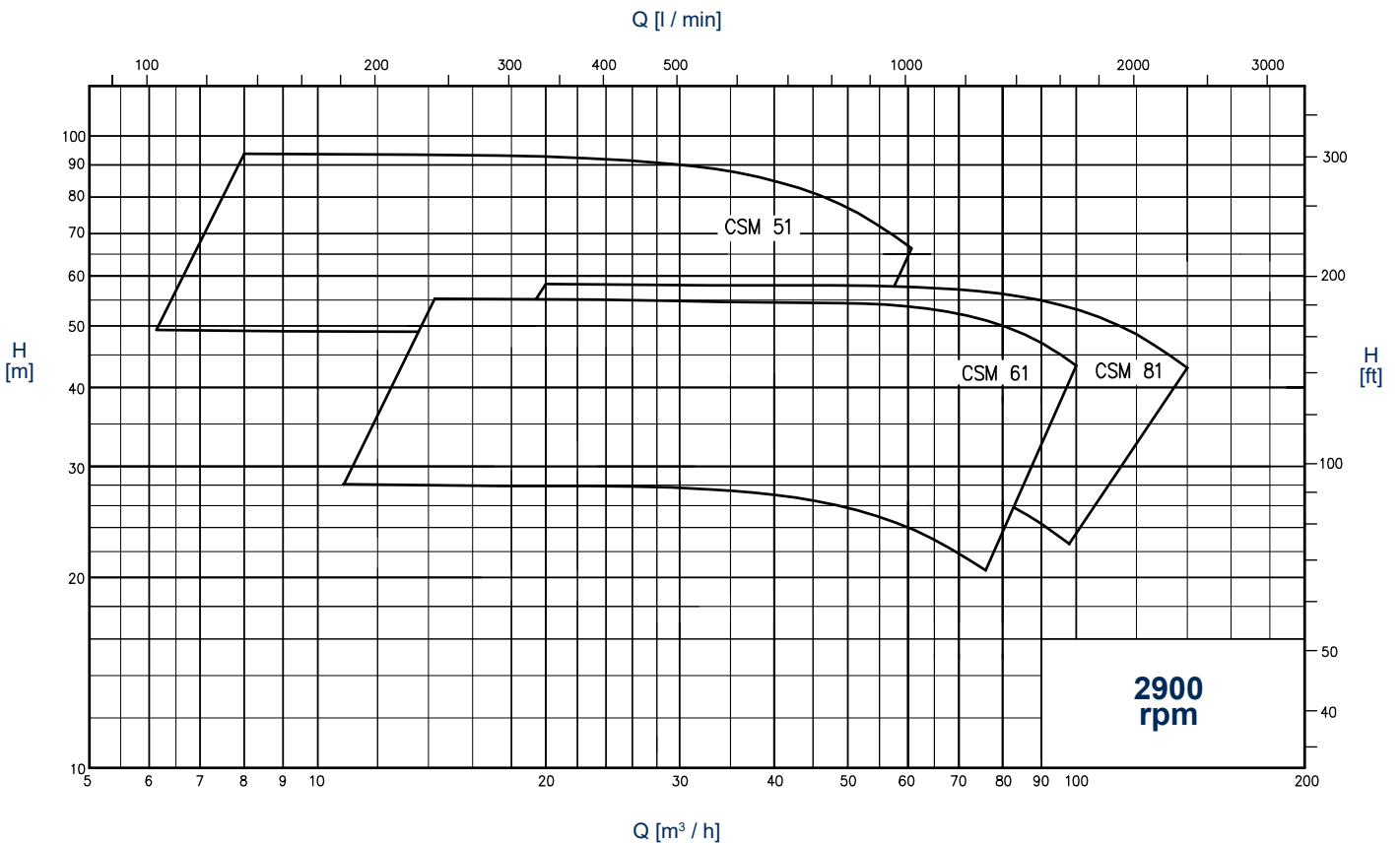

OVERALL DIMENSIONS CSM MULTISTAGE

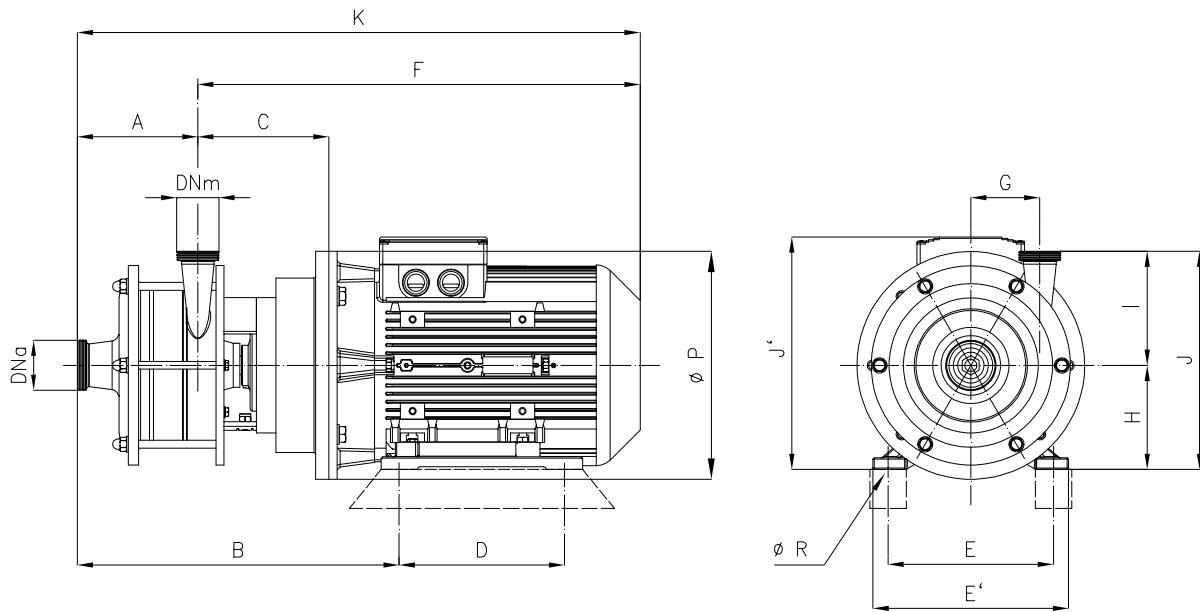

Dimensions not binding - DN = DIN 11851 male threaded connections, with standard IEC/EN motors

Pump type	kW	DN _a	DN _m	A	B	C	D	E	E'	F	G	H	K	ØP	ØR	I	J	J'
CSM 42	11	50	40	139	463	216	210	254	300	694	86	160	883	350	14	203	363	357
CSM 42	18,5	50	40	139	463	216	254	254	300	694	86	160	883	350	14	203	363	357
CSM 43	18,5	50	40	192	516	216	254	254	300	694	86	160	886	350	14	203	363	357
CSM 43	22	50	40	192	529	216	241	279	340	776	86	160	968	350	14	203	363	442
CSM 44	22	50	40	245	582	216	241	279	340	776	86	180	1021	350	14	203	383	442
CSM 52	15	65	50	139	463	216	210	254	300	694	86	160	833	350	14	205	365	357
CSM 53	22	65	50	192	529	216	241	279	340	776	86	180	968	350	14	205	385	442

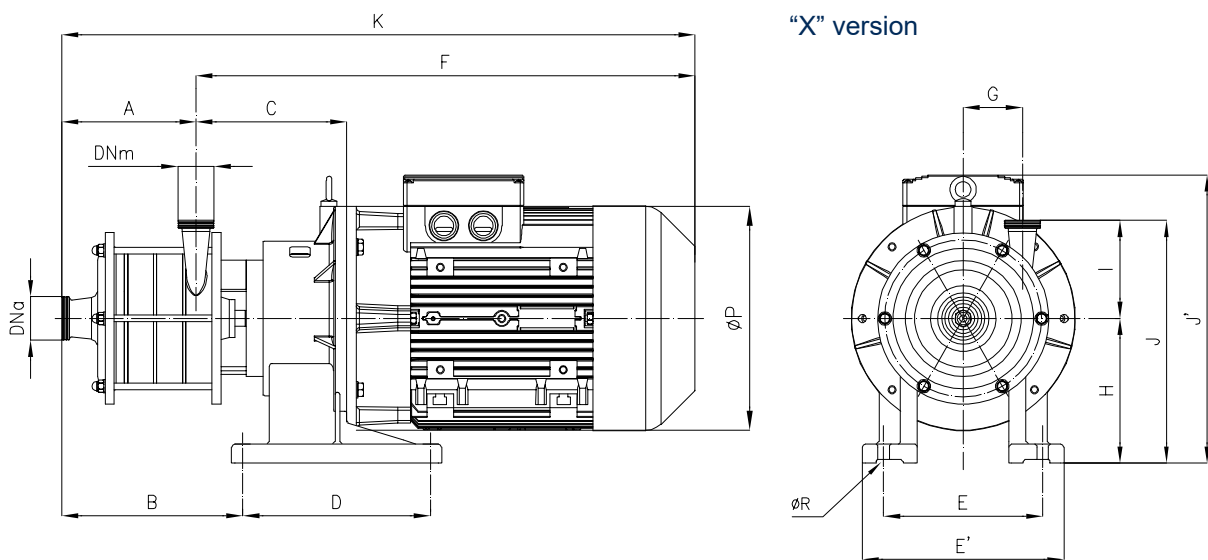

"X" version

Dimensions not binding - DN = DIN 11851 male threaded connections, with standard IEC/EN motors

Pump type	kW	DN _a	DN _m	A	B	C	D	E	E'	F	G	H	K	ØP	ØR	I	J	J'
CSMX 44	30	50	40	245	345	284	335	284	360	943	86	258	1188	400	21	203	461	563
CSMX 53	30	65	50	192	292	284	335	284	360	943	86	258	1135	400	21	205	463	563
CSMX 54	30	65	50	245	345	284	335	284	360	943	86	258	1188	400	21	205	463	563
CSMX 54	37	65	50	245	345	284	335	284	360	943	86	258	1188	400	21	205	463	563

OVERALL DIMENSIONS CSM SINGLE-STAGE

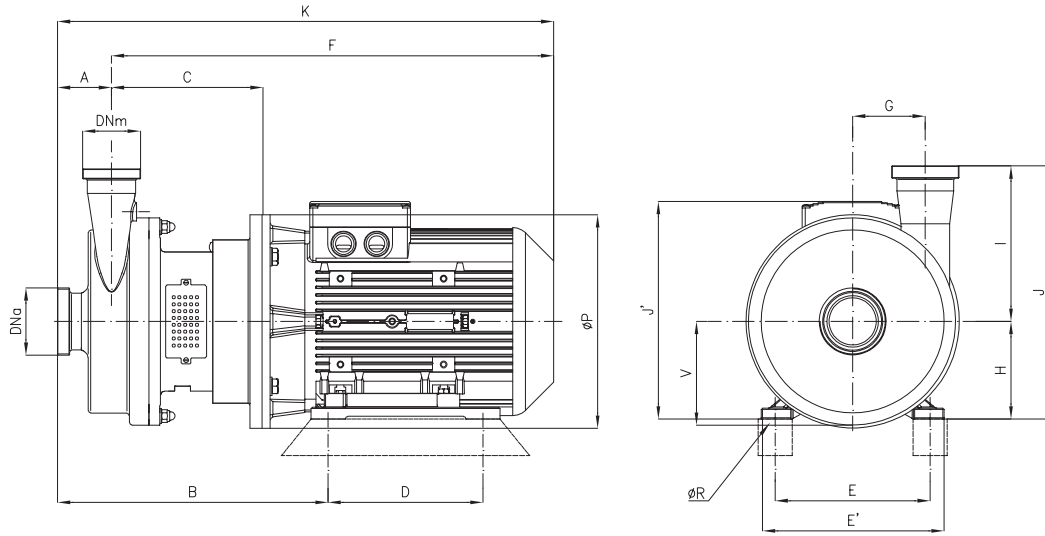

Dimensions not binding - DN = DIN 11851 male threaded connections, with standard IEC/EN motors

Pump type	kW	DNa	DNm	A	B	C	D	E	E'	F	G	H	K	ØP	ØR	I	J	J'	V
2900 rpm																			
CSM 51	15	65	50	73	431	250	210	254	300	728	140	160	801	350	15	240	400	357	195
CSM 51	18,5	65	50	73	431	250	254	254	300	728	140	160	801	350	15	240	400	357	195
CSM 51	22	65	50	73	444	250	241	279	340	810	140	180	883	350	15	240	420	442	195
CSM 61	11	80	65	84	445	253	210	254	300	731	100	160	815	350	15	250	410	357	170
CSM 61	15	80	65	84	445	253	210	254	300	731	100	160	815	350	15	250	410	357	170
CSM 61	18,5	80	65	84	445	253	254	254	300	731	100	160	815	350	15	250	410	357	170
CSM 61	22	80	65	84	458	253	241	279	340	813	100	180	897	350	15	250	430	442	170
CSM 81	11	100	80	100	461	253	210	254	300	731	120	160	831	350	15	255	415	357	170
CSM 81	15	100	80	100	461	253	210	254	300	731	120	160	831	350	15	255	415	357	170
CSM 81	18,5	100	80	100	461	253	254	254	300	731	120	160	831	350	15	255	415	357	170
CSM 81	22	100	80	100	474	253	241	279	340	813	120	180	913	350	15	255	430	442	170

"X" version

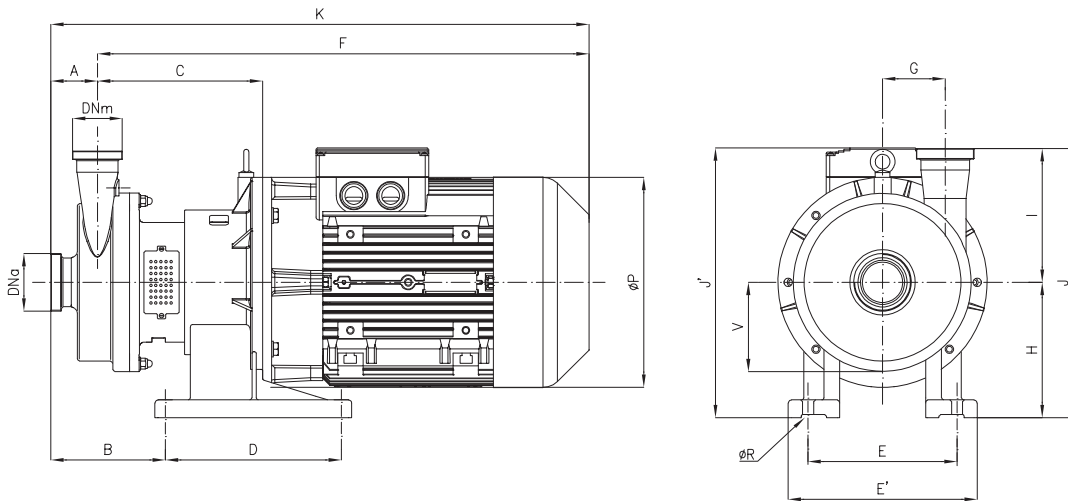

Dimensions not binding - DN = DIN 11851 male threaded connections, with standard IEC/EN motors

Pump type	kW	DNa	DNm	A	B	C	D	E	E'	F	G	H	K	ØP	ØR	I	J	J'	V
2900 rpm																			
CSMX 51	30	65	50	73	216	325	335	284	360	935	140	258	1008	400	21	240	498	558	195
CSMX 61	30	80	65	84	227	328	335	284	360	938	100	258	1022	400	21	250	508	558	170
CSMX 81	30	100	80	100	243	328	335	284	360	938	120	258	1038	400	21	255	513	558	170
CSMX 81	37	100	80	100	243	328	335	284	360	938	120	258	1038	400	21	255	513	558	170



C.S.F. Inox S.p.A. Strada per Bibbiano, 7 - 42027 Montecchio E. (RE) - ITALY EU

Ph +39.0522.869911 r.a. - Fx +39.0522.865454 - italia@csf.it - www.csf.it

Export Department • Commercial Étranger • Comercial Extranjero

Ph +39.0522.869922 - Fx +39.0522.869841 - export@csf.it - www.csf.it



All the instructions, data and representations (in whatever way executed) listed in this publication are indicative and do not binding. C.S.F. does not stand surely or undertake any obligation for the utilisation of this document and for the information contained. In particular, it does not guarantee against omissions or errors of the data and drawings here indicated. Notice that the technical specifications, information and representations in this document are merely indicative and approximate. C.S.F. INOX reserves the right at any moment and without notice to modify the data, drawings and information indicated in this document.